

APPLICATION:

JOB NAME:

QUANTITY: ITEM NO.

PRODUCT NAME:
PRE-RINSE SPRING SINGLE WALL MOUNT WITH WALL BRACKET & ADD-ON FAUCET

SPECIAL CONFIGURATION
 CHECK BASE MODEL AND OPTIONS

MODEL:

34568 WITH 6" SWING SPOUT

34576 WITH 8" SWING SPOUT

34585 WITH 10" SWING SPOUT

34592 WITH 12" SWING SPOUT

34606 WITH 14" SWING SPOUT

34614 WITH 16" SWING SPOUT

OPTIONS OR MODIFICATIONS:

SUPPLY LINES (24" OR 36") CIRCLE LENGTH

ADD-ON FAUCET (6", 8", 10", 12", 14", 16") CIRCLE

IN-LINE DUAL CHECK VALVE

BRUSH

VANDAL RESISTANT KIT

HANDLES (CROSS OR WRIST) CIRCLE STYLE

OTHER _____

FEATURES:

MAIN CONTROL VALVE

- * SINGLE WALL MOUNT
- * INTERNAL SPRING LOADED CHECK VALVES
- * SWIVELLING SEAT DISKS
- * STEM - RIGHT HAND SWIVEL
- * HOT AND COLD INDEX BUTTONS INCLUDED
- * STAINLESS STEEL SEATS, SEAT SCREWS AND HANDLE SCREWS

ADD-ON CONTROL VALVE

- * STEM - RIGHT HAND SWIVEL
- * HOT INDEX BUTTON
- * SWIVELLING SEAT DISKS
- * STAINLESS STEEL SEATS, SEAT SCREWS AND HANDLE SCREWS.

HOSE

- * 36" LENGTH
- * STAINLESS STEEL END FITTINGS
- * STAINLESS STEEL EXTERNAL JACKET
- * 3-PLY FIBER REINFORCED INTERNAL RUBBER HOSE
- * REPAIRABLE IN FIELD WITH SIMPLE TOOLS

ULTRA SPRAY VALVE

- * LOWEST ENERGY USER - 1.15 GPM @ 60 PSI
- * CLEANS FASTER - TEST PROVEN
- * ENGINEERED TO LAST - NO 'O' RINGS TO LEAK
- * INTERCHANGEABLE - FITS ALL BRANDS

WALL BRACKET

- * ADJUSTS FROM 2" TO 12"

SYSTEM LIMITS

- * TEMP: 40°F MIN. TO 140°F MAX. STATIC
- * PRESSURE 200 PSI MAX. STATIC
- * SHIPPING WEIGHT: 12.0 LBS

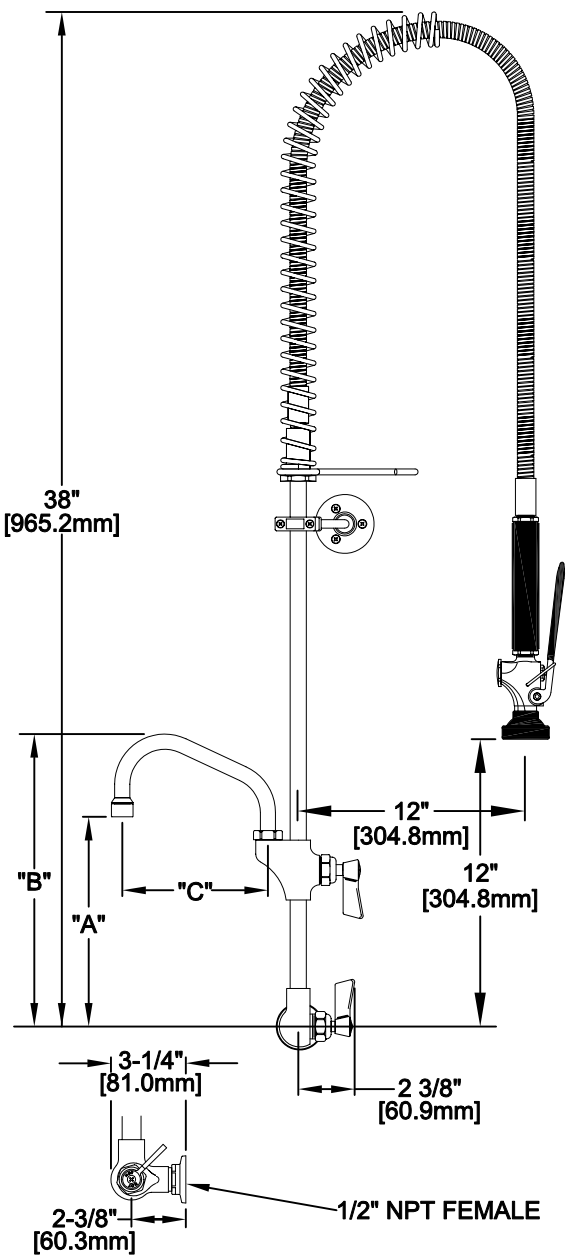

ROUGH-IN	MODEL	DIM "A"	DIM "B"	DIM "C"
<p>1/2" NPT MALE*</p> <p>*NIPPLE NOT INCLUDED</p>	34568	8-3/4" [221.3mm]	12-3/8" [313.3mm]	6" [152.4mm]
	34576	9" [227.6mm]	12-7/8" [326.0mm]	8" [203.2mm]
	34584	9-5/8" [243.5mm]	13-3/8" [340.3mm]	10" [254.0mm]
	34592	10-1/4" [259.4mm]	13-7/8" [351.4mm]	12" [304.8mm]
	34606	10-5/8" [275.0mm]	14-3/4" [373.7mm]	14" [355.6mm]
	34614	11-1/2" [292.1mm]	15-3/8" [389.5mm]	16" [406.4mm]